

Diâmetro mínimo sem ferramenta

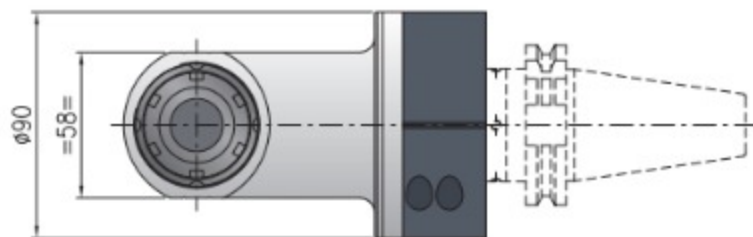

Relação
1:1

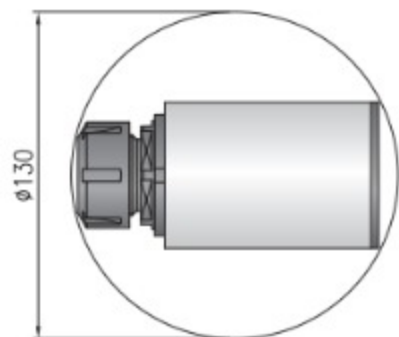

RPM
6.000 min⁻¹



Carga axial max.
510 N



Torque
30 Nm



Peso
5,4 kg



Pinça
ER-25 \varnothing 1/16 mm

*** ACESSÓRIOS INCLUSOS:**

- Caixa especial
- Chaves
- Tubo de graxa
- Instruções de uso

Tabela Técnica

 Mesmo sentido da rotação do fuso da máquina

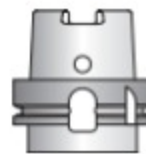

Mandril	DIN-69871		CAT		MAS-BT		HSK		CAPTO		KM
Tamanho	40	50	40 *	50 *	63-80	100	C5-C6	C8	63		
I	65-80	80-(110*)	65	80	65-80-(110*)	80-(110*)	65-80-(110*)	80-(110*)	65-80-(110*)		
S	35	35	35	41	42	45	38	40	40		
L	150	150	150	156	157	160	153	155	155		

*opcional

* Pronta entrega, demais mandris sob consulta.

Opções sob encomenda:



bar max
12

Refrigeração
através do
pino



bar max
12

Refrigeração
interna através
do mandril



min⁻¹
8.000

High speed RPM max.



Ø mm
16

Porta fresa



Ø mm max.
16

Weldon



HSK-32

(Troca rápida)



ER-25/ER-16

Duplo mandril